

**The Arbors at Towne Lake Homeowners
Association**

Architectural Committee Guidelines and Review Procedures

Table of Contents

1. INTRODUCTION AND OVERVIEW.....	3
1.1 Definition of Modifications.....	4
1.2 Who is subject to the approval process?.....	5
1.3 Who administers the approval process?	5
1.4 Application for Review	5
2. DESIGN REVIEW PROCEDURES.....	6
2.1 Modifications Review	6
2.2 Regulatory Compliance.....	7
2.3 Final Review.....	7
2.4 Appeals.....	7
3. ENFORCEMENT	8
3.1 Responsibilities of ACC.....	8
3.2 Remedies	8
3.3 Waiver, Amendment and Third-Party Benefit	9
3.4 Non-Liability of the ACC.....	9
3.5 Accuracy of Information	9
3.6 Applicant Representation	10
4. DESIGN GUIDELINES	10
4.1 Architectural Design Guidelines	10
4.1.1 Foundations/Retaining Walls.....	10
4.1.2 Painting.....	10
Siding, Stucco, and Trim	10
Windows, Shutters, Louvers, and Doors	11
4.1.3 Exterior Body and Trim Materials.....	11
4.1.4 Windows.....	11
4.1.5 Roof.....	12
4.1.6 Antennas & Satellite Dishes	12
4.1.7 Chimneys	12
4.1.8 Decks & Railings.....	12
4.1.9 Screened Porches, Sunrooms & Room Additions	13
4.1.10 Stoops, porches, and steps	13
4.1.11 HVAC.....	13
4.2 Site Design Guidelines	13
4.2.1 Walls & Fences.....	13
4.2.2 Sports Equipment, Tennis Courts & Tree Houses.....	14
4.2.3 Detached Buildings.....	15
4.2.4 Exterior Lighting.....	15
4.2.5 Bed Walls, Edging Material and Mulch	15
4.2.6 Plant Material.....	15
4.2.7 Animal Houses.....	16
4.2.8 Mailboxes	16
4.2.9 Fire Hydrants	16
4.2.10 Lawn Furniture	17
4.2.11 Yard Statuary and Ornamentals.....	17
4.2.12 Gazebos & Arbors	17
4.2.13 Swimming Pools & Hot Tubs.....	17
4.2.14 Tree Removal.....	17
4.2.15 Driveways.....	18
5. USE RESTRICTIONS & RULES (Image).....	18
5.1 Architectural Standards	18

5.2 Use of Lots	19
5.2.1 Signs	19
5.2.2 Vehicles	19
5.2.3 Animals and Pets	21
5.2.4 Unsightly or Unkempt Conditions	21
5.2.5 Garbage Cans, Woodpiles, Hosepipes, Recycle	22
5.2.6 Flags	22
APPENDIX A: Approved Fencing	24
The following are the only approved stain colors for use:	24
A.1 Shadowbox Privacy Fencing	24
A.2 Cedar Split Rail Fences	25
A.3 French Gothic Spaced: A.4 Wrought Iron or Aluminum Fencing:	26

1. INTRODUCTION AND OVERVIEW

The Architectural Control Committee (*hereinafter referred to as the ACC*), was originally formed as a sub-committee of the Arbors Homeowners' Association (*hereinafter referred to as the HOA*) to maintain a higher standard in quality and design of the homes governed by the HOA, ensuring a higher market premium for homes in our area. Today, the ACC not only regulates ongoing compliance with these quality standards but also manages the adherence of all the HOA's covenants and ordinances concerning the image of our neighborhood. This guideline is provided to form the basis for a common understanding of the design objectives and standards by all those involved in creating this community and most importantly by the present and future residents. These Procedures will be used by the ACC to review plans and specifications pursuant to the provisions of the applicable Declaration of Covenants, Conditions, and Restrictions of the Arbors community. The ACC intends to be fair and objective in the design review process and impartial and understanding of individual goals.

1.1 Definition of Modifications

A modification is defined as an alteration, addition or deletion to any of the following:

➤ Landscaping and Modifications to Land

1. Plant Materials
2. Tree Removal
3. Change of Grade or Topography
4. Drainage
5. Retaining Walls and Foundations
6. Bed Walls, Edging Materials, Mulch
7. Pathways, Sidewalks, Driveways
8. Exterior Lighting
9. Fences and Walls
10. Gazebos, Arbors, Pergolas
11. Benches, Lawn Furniture
12. Basketball Goals, Play Equipment, Swing Sets, Sports Equipment
13. Animal Houses
14. Swimming Pools, Hot Tubs, Jacuzzis, Fountains & Decorative Pools/Ponds
15. Tennis Courts
16. Mailboxes
17. Trashcans, Hose Screens
18. Antennas, Satellite Dishes

➤ Structural Modifications

1. Exterior Materials; Siding & Trims
2. Doors, Windows, Garage Doors, Shutters and Window Treatment
3. Exterior Wall Finishing; Paint, Stains, Brick, Stone etc
4. Decks and Railing
5. Screened Porches, Sunrooms, Any Exterior Visible Room Addition
6. Terraces, walls, drives, turn-a-rounds and walkways
7. Detached Structures
8. Roofs
9. Awnings
10. Chimneys
11. Stoops & Steps
12. Any other exterior items related to the image of your home, but not specifically mentioned on this list

Design standards or elements incorporated into new houses by builders according to plans approved by the developer shall not be considered precedent setting for modifications to existing houses.

After a new house has been completed according to the approved plans, the ACC becomes responsible for reviewing all changes to the exterior of the structure and site. The ACC typically consists of volunteer members appointed by the Board of Directors of your HOA.

1.2 Who is subject to the approval process?

All property owners are responsible for obtaining the necessary review and approvals to comply with the terms of the Arbors Covenants, Conditions, and Restrictions. While the original builder of your home was responsible for new construction, you, the current homeowner are responsible for anything that is a modification or deviation from the original house and/or landscape plans. There are no exemptions or automatic approvals. Each application is reviewed on an individual basis. When you purchased your home, your realtor would have given you a copy of the HOA Covenants and you would have signed “off” on, or agreeing to abide by, the terms and conditions therein.

1.3 Who administers the approval process?

The final authority for administration of the approval process lies with the HOA. However, the Committee may delegate the responsibility for administering these procedures or parts thereof to a third party representative. The selection of the ACC representative that will handle your application is based on professional qualifications and an ability to understand the overall, as well as specific, development objectives.

1.4 Application for Review

Applications for modifications must be made on the ACC Review form as found on the Arbors Web Site and may change from time to time. This document must be submitted to:

Sixes Management Group
2230 Towne Lake Pkwy. Bldg. 500, Ste. 110
Woodstock, Georgia 30189
modifications@sixesmanagement.com
(770) 575-0943

There are many “routine” applications, such as repainting a home with the same color as previously applied. These routine requests are normally approved within five to ten days. All projects which require the full ACC committee’s input or require research and potentially consultation with third party experts will be rendered and mailed no later than forty-five (45) days after the Committee meeting in which it was discussed.

The Committee’s decision may be:

1. Approval of Modification
2. Conditional Approval with stipulations
3. Denial of Modification
4. Conditional Denial pending submission of additional requested information
5. Deferral of decision until a specific later date pending on-site review by the ACC

Approved applications/projects remain valid for 12-months from the date of approval. Should an approved project take longer than a year to complete, a new application or approved request for extension is required.

2. DESIGN REVIEW PROCEDURES

2.1 Modifications Review

All applications for modifications must be submitted to the Architectural Control Committee in accordance with the procedures outlined below **PRIOR TO MAKING ANY MODIFICATIONS**. If the modification is extensive or the applicant files an appeal based upon an application denial, and the ACC deems it necessary to hire a third party expert, the fees associated with retention of this third party expert shall be passed onto the applicant. When a third-party expert is required, the homeowner shall be advised of this requirement before engaging such expert, and the applicant will be required to either contract with the expert prior to the appeal or pay for these services in advance. At no time will the ACC contract with any party on behalf of a homeowner. Failure to follow these guidelines will result in a denial of the modification request.

Please note the Board may levy immediate fines if the owner begins a project without the approval of the ACC.

Step 1

Be Courteous to Neighbors.

Although neighbors' approval may not be necessary, it is always a good idea to discuss your intentions with any neighbor immediately facing your home, whether they will see the results of your project or not.

Homeowners submitting requests to install fencing, plant materials which may eventually encroach upon property lines, other modifications on or close to the property line, or any modification which may impact your neighbor in some way, should particularly be discussed with your neighbor prior to signing and submitting your request forms to the ACC. This could alleviate any potential friction with your neighbors and ensure that your project isn't delayed later by neighbor objections.

Step 2

The Applicant must submit an application and one (1) set of plans drawn to scale indicating the extent of proposed improvement in sufficient detail to allow review. This must include drawings of exterior building, elevation changes, material, finish & color schedules and any construction details. A landscape plan must show placement, number, species and size of proposed landscape additions. Any modification other than a color change requires a site plan of at least (1" = 20') showing the following:

1. Property lines
2. Setback and easements
3. Footprint of house and driveway, sidewalks, decks, patio retaining walls, etc.
4. Existing trees and landscaping
5. All proposed improvements, dimensioned to properly locate them from the house or property line.

The modification submittal must be submitted as indicated in Section 1.4 of this document.

Step 3

After review of application the Property Manager will provide a written approval response to the submittals.

The Property Manager as noted in Par. 1.4 above has the responsibility of conveying the decision made by the ACC.

Step 4

For Moderate or Major Projects, or any submittal that is approved with stipulations, the Property Manager should be contacted, within seven days (7) of completion, to schedule an on-site review for verification and conformance with the approved submittals. Notifying the Property Manager as to completion and scheduling the time of review will be the responsibility of the applicant.

The ACC may, at its sole discretion, inspect the state of the approved project anytime until it has been signed off.

2.2 Regulatory Compliance

Plans submitted for Modifications review must comply with all applicable building codes, zoning regulations and the requirements of all agencies having jurisdiction over the project. It is the responsibility of the Applicant to obtain all necessary permits, inspections and final Certificate of Occupancy. Regulatory approvals do not preclude the authority and responsibility of the ACC for design review and vice versa.

2.3 Final Review

The Committee's final approval of your project application constitutes a binding agreement between the Applicant and the Association. **Any deviation from the approved plans must be resubmitted** to the Committee for approval. A Committee decision is based on a simple majority and shall not be arbitrary or capricious. The Committee may, at its discretion, assist the Applicant by suggesting alternative design solutions.

2.4 Appeals

Any decision reached by the ACC may be appealed to the Board of Directors. Within 14 days after a decision has been rendered, the Applicant may file a written appeal with the Arbors Board of Directors at the address specified in Par 1.4 above.

Technical design information supporting the appeal request must be included with the request. All appeals will be reviewed on a case-by-case basis, and the granting of an

appeal for one residence for a particular situation does not imply or warrant that a similar appeal would be granted on another residence.

Each case will be reviewed on its own design merits, and in keeping with the overall objectives of the Design Guidelines.

Please remember that if the applicant files an appeal based upon an application denial, and the ACC deems it necessary to hire a third party expert, the fees associated with retention of this third party expert shall be passed onto the applicant.

3. ENFORCEMENT

3.1 Responsibilities of ACC

The ACC is responsible for keeping all homes and homeowners in compliance with the terms and conditions of the Association's governing documents. The ACC is specifically responsible for ensuring homeowner compliance with regards to (including but not limited to):

1. Use of Lots
2. Signage
3. Vehicle Parking & Speed
4. Pets and Animals
5. Nuisance and Disruptive Activity
6. Property Maintenance
7. Antennas
8. Landscaping
9. Tree Removal
10. Lighting
11. Garbage Cans, Woodpiles, Clotheslines
12. Fences
13. Exterior Colors of Homes
14. Mailboxes
15. Detached Structures
16. Pools and Hot Tubs
17. Garage Conversions
18. Structural Modifications or Additions

To this end, members of the Property Management Company and the ACC regularly inspect the visual impact of every home in the neighborhood and may, from time to time, bring to the attention of the homeowners where they are not in compliance. Should any particular homeowner consistently break the Covenants, they are reported to the HOA who, in their discretion, will impose fines, which becomes a lien on your home. Specific rules are detailed in Section 5 of this document.

3.2 Remedies

The provisions for enforcement of the Declaration of Covenants Conditions and Restrictions as it applies to non-conformance of the architectural guidelines as stipulated in the Covenants, Conditions and Restrictions shall apply to the enforcement of these Design Review Procedures and Guidelines, in addition to any other available remedies.

In order to ensure compliance with the Association's governing documents and these Design Guidelines, the Association has the power and authority to:

1. Impose fines
 - a. Immediate fines for any modification begun without submission of a Modification Request or prior to receiving an approval from the ACC for any requested modification (\$250.00 per violation as of the latest revision of these Design Guidelines)
 - b. Continuing fines for non-remedied violations
2. Exercise the Right of Abatement, the right to enter property with notice and extinguish, remove or repair the violation at the homeowner's expense
3. Require Specific Performance (Covenants, Bylaws, Design Guidelines, and other Rules and Regulations as promulgated by the Board of Directors). This might include removing any unapproved modification and/or returning the property to the condition prior to any work and/or modification that may have occurred.

3.3 Waiver, Amendment and Third-Party Benefit

The ACC maintains the right, from time to time, with concurrence of the Board of Directors, to waive, amend or modify these Procedures and Guidelines. Neither the ACC nor its agents, representatives or employees shall be liable for failure to follow these Procedures and Guidelines as defined herein. These Procedures and Guidelines confer no third-party benefit or rights upon any entity, person or applicant.

3.4 Non-Liability of the ACC

Neither the Board of Directors, ACC, nor its respective HOA members, Chairperson, Secretary, successors, assigns, agents representatives or employees shall be liable for damages or otherwise to anyone submitting plans to it for approval, or to any Applicant by reason of mistake in judgment, negligence of non-feasance, arising out of any action of the ACC with respect to any submission, or for failure to follow these Procedures or Guidelines. The role of the ACC is directed toward review and approval of site planning, appearance, architectural vocabulary and aesthetics. The ACC assumes no responsibility with regard to design or construction, including without limitation, the civil, structural, mechanical, plumbing or electrical design, methods of construction, or technical suitability of materials.

3.5 Accuracy of Information

Any person submitting plans to the ACC shall be responsible for verification and accuracy of all components of such submission, including, without limitation, all site dimensions, setbacks, easements, grades, elevations, utility locations and other pertinent features of the site or plans. Any persons submitting plans to the ACC shall be responsible for contacting all impacted neighbors prior to signing and submitting the application. Failure to contact appropriate neighbors, if neighbors oppose your plans, may result in withdrawal of the ACC approval of the application.

3.6 Applicant Representation

The Applicant represents by the act of entering into the review process with the ACC that all representatives of Applicant, including, but not limited to, Applicants architect, engineer, contractors, subcontractors, and their agents and employees shall be made aware by the Applicant of all applicable requirements of the ACC and shall abide by these Procedures, the Guidelines and the Covenants, Conditions and Restrictions with respect to approval of development plans and specifications.

4. DESIGN GUIDELINES

Remodeling and additions to existing structures are required to follow the same guidelines as new construction. Criteria governing site location, grading/excavation, structures, roofs, landscape and all other components will remain the same as the previous submittal. Of particular concern will be setbacks, height limits, skylights, solar collectors, recreational features, lighting, antennas, and satellite dishes. Approval from the ACC is required for all of these conditions and all remodeling just as it is for new construction. The Guidelines that follow address a broad range of exterior building and site conditions. They are not intended to be all-inclusive, but rather a guide, by which a high quality community can be planned, designed, built and maintained.

Note: Please remember that all proposed new construction and modifications to existing buildings or landscapes must be submitted, reviewed and approved by the Architectural Control Committee **before** any construction begins. (See Section 1.1 for definition of Modifications.)

4.1 Architectural Design Guidelines

4.1.1 Foundations/Retaining Walls

Exposed concrete block or poured concrete foundations and site retaining walls must be covered with stone, brick, or stucco to complement the house materials. Retaining walls that attach to the residence should utilize the same materials as the wall that they adjoin. Crosstie timber walls may only be used if they are in the rear yard of the residence and are approved by the ACC. Wall height is limited to 6 feet.

4.1.2 Painting

Exterior Body

All exterior paint colors must be approved by the ACC. Paint colors to be approved include, but are not limited to, exterior trim, windows, doors, shutters, gutters, garage doors, railings and decks. When submitting paint colors, include paint chip, specify manufacturer, color name, and color number if applicable (ie., Porter— Jade Blue 16306). The ACC may require that the applicant paint a section of the house (4' x 4') with the proposed paint color prior to approving the request.

Siding, Stucco, and Trim

Primary colors for siding, stucco and trim must be confined to lighter earth tones that are compatible with the natural environment (“primer” white paint is not an accepted color). Stucco and synthetic stucco must be painted or integrally colored. Colors for windows, doors, louvers, gutters and downspouts must be compatible with primary and trim colors.

Windows, Shutters, Louvers, and Doors

Windows, shutters, louvers, and doors (including garage doors) shall be painted a single color (ie., no two-tone.) Some carriage style garage doors will be considered for two-tone color.

Exterior Additions and Modifications

For additions and modifications, house and trim colors and materials should be identical to that on the original residence, except where unavailability of original materials or improved materials technology dictates a change.

Painting a Pre-Existing Color

Painting with no change in existing color will be approved subject to the homeowner signing and submitting a request form stating that they have and will use the formulae for existing colors.

4.1.3 Exterior Body and Trim Materials

The use of vinyl or aluminum siding or trim products is not approved.

All siding and exterior trim must be marketed and warranted as being able to receive and retain paint.

Cement fiber siding such as *Hardiplank*, painted to match the existing siding, is permitted to replace original siding.

Fascia, sill nose, brick mould and other exterior trim composed of Cellular PVC or other non-rot materials that are marketed and warranted as being able to receive and retain paint and identical in size and shape to the original, may be used to replace wood products as long as the end color scheme matches existing color schemes they are replacing.

Any changes to original colors or structural and trim materials must be noted on the Modification request submittal and be approved by the ACC.

4.1.4 Windows

All window treatments facing the street must be lined in white or ivory to give the community a common look from outside. The type of window treatments may include, but are not limited to, white sheers, white blinds, white plantation shutters, or white lined curtains.

Any deviation to other coverings on the window will be considered on a case by case basis; this includes, but is not limited to stained glass panels, plastic art window coverings, window film, stained wood window coverings.

Original window material and design for The Arbors are wood, double-hung formats. Storm windows are not permitted on front windows.

The HOA has, however, identified acceptable non-rot alternatives to wood windows. Homeowners desiring to install a window made of a material other than wood may submit an application, with samples, to the ACC for review and approval.

The change of glass from regular to Low-E and changes in grill placement, (ie between glass panes, pop-in grills, or architecturally correct grills) will be approved, provided the change is

made to all windows of a particular façade of the home, (naturally excluding leaded glass or stained windows), and the grill patterns match existing patterns of that home. Any change in grill pattern requires ACC approval. eg: Colonial to Prairie or Gothic styles, and so on.

Cellular PVC and other synthetic window trim pieces that are **marketed and warranted as being able to receive and retain paint**, may be used to replace identical wood trim **without prior approval** from the ACC, so long as the replaced trim is painted to match the existing trim.

4.1.5 Roof

Primary residential roofing materials must be dimensional or architectural asphalt shingles; colors acceptable are Weathered Wood, Slate Blend, and Black Blend. Sheet metal and PVC work such as roof caps, flashings and plumbing vents must be painted to match the roof colors. Roof stacks and plumbing vents must be placed on the rear slopes of roofs and painted to match the roof color.

New Construction Projects

As a general rule, any new roof on additions or new structures should be gabled or hipped with a minimum pitch of 10:12. All front facing gables may not be below 10:12 or over 16:12 and variances will only be considered on one-story homes. Front facing gables must have cornice returns and all roofs must have fascia boards and enclosed cornices.

No skylights may be placed on the front slope of any roof and must have bronze or black anodized frames.

New roof structures of any kind require county building permits, and said required permits may be required by the ACC prior to approval.

4.1.6 Antennas & Satellite Dishes

Antennas, other than satellite dishes for television reception, are **NOT** permitted.

Satellite dishes, to the extent possible, should be located as inconspicuously as possible consistent with proper operation. Requested placement in order of preference is:

1. On the rear of the house below the ridge line
2. On the side of the house below the roof peak

4.1.7 Chimneys

Chimneys framed to receive prefabricated fireplaces and flues must be finished in appropriate materials and colors to blend with the primary house decor. Chimney caps must be fabricated metal painted an approved color.

4.1.8 Decks & Railings

Approved deck materials are *cedar, red wood and pressure treated pine*. Railing and step design and details must be approved by the ACC. Decks may be stained or painted with approved colors to match home. Vertical supports for wood decks must be a minimum 6"x6" wood post or a minimum of 8"x8" stucco or brick columns. Metal columns must be boxed in wood, stucco or brick to the above requirements.

New composite materials or low maintenance decking such as TREX, must be submitted for approval before utilization.

It is also the homeowner's responsibility to comply with code and other regulatory agencies regarding the engineering and/or safety of deck construction. Building permits are required by county. Approval by the ACC does not imply approval by these authorities.

4.1.9 Screened Porches, Sunrooms & Room Additions

Detailed plans including elevations, a list of all materials, including:

1. Windows
2. Roofing
3. Siding (if any)
4. Decking
5. Color selections

Must be submitted when applying for new sunrooms, screened or unscreened porches and other room additions to your home. Materials must be consistent with materials on the existing home and painted or stained to match.

4.1.10 Stoops, porches, and steps

Stoops, porches, and steps on front and sides of houses shall be brick, stone, or stucco. No exposed concrete is allowed. All additions must be approved by the ACC. All roofs, overhangs, etc. must have matching color composition shingles or metal roofing. Canvas awnings are not allowed on the fronts of residences; they may be used on the side or rear of residences with ACC prior approval.

4.1.11 HVAC

Window mounted HVAC units are not permitted.

4.2 Site Design Guidelines

4.2.1 Walls & Fences

No walls or fences shall be erected or maintained on any lot nearer to the street than the rear of the residence. All fences and walls shall be approved by the ACC pursuant to the Design Standards adopted by the Arbors Homeowners Association. Metallic link fences are not permitted except with tennis courts as defined in Section 4.2.

All fence heights/material must be consistent with the standards mentioned below. No fence or wall may be installed which will impede the natural flow of water across the lot. There are several approved fences to choose from, which are detailed here and pictured in our Appendix A.

Privacy fencing is allowed for all lots and must consist of a cedar shadow box design meeting governing codes and may be a maximum of 60" in height and/or not exceed the maximum allowed by code. The best visual side of the fence shall be placed toward the outside, offering onlookers the most pleasing view. All fencing surrounding pools must be a minimum of 5' in height per county code.

Adjacent property owners wishing to install approved fencing material shall install same directly upon the property line to prevent un-maintained vegetation from growing in between the two fences.

Cedar Split Rail fences

1. Natural wood finish only
2. Fences should be placed on the property line or well inside your side of the property line.
3. Neighbors may not tie into neighbors fencing unless on the property line. Common fences are permissible with written permission of your neighbor, and the common element shall be installed on the property line.
4. 38" and 48" wire mesh on interior is permissible.
5. Substitutes such as "Appalachian treated pine" will be considered.

French Gothic Picket Fence

1. Natural wood finish only, **Wood only, no PVC**
2. 3" pickets, 2" spacing between pickets
3. 4x4 wood posts, 8 foot lengths between posts
4. 42" and 48" heights only
5. Wrought Iron Fence (5' minimum surrounding pools per county code)
6. Black only; Iron or Aluminum only, no PVC
7. 5/8" pickets, 3 13/16 to 4" spacing between pickets
8. 2" metal posts or 12" brick or stucco posts that match house
9. 6' between posts
10. 42", 48", and 60" heights only

Shadow Box Privacy Fence

1. 4"x4" posts; maximum height of 60" (5 Feet)
2. 1"x 6" boards; maximum height of 60" (5 Feet)
3. 3" to 4" spacing between boards on each side
4. 2x framing
5. Cedar or comparable wood
6. 60" maximum height (5 Feet)

4.2.2 Sports Equipment, Tennis Courts & Tree Houses

All play equipment including **basketball backboards** must be approved by the ACC in advance of its placement. The play equipment must be located where it will have a minimum visual impact on adjacent properties and streets. Fixed play equipment should be naturally colored wood or metal.

All **tennis courts** and play structures shall be located at the rear of the dwelling, or on the inside portion of corner lots within the setback lines.

No play equipment, other than basketball backboards, shall be constructed on any part of a lot located in front of the rear line of the residence constructed thereon, and any such play equipment must have approval of the ACC and include sufficient landscaping treatment acceptable to the ACC. Permanent basketball goals must be mounted on freestanding black or neutral colored metal poles (i.e. not attached to the house), and have standard-white, gray or clear backboards. Portable basketball goals must be kept on owner's property and must be of natural colors.

Tree houses are not encouraged; however, they may be approved if the design is conservative and does not conflict with the style and architecture of the residence. It should not encroach visually on neighbors, views or privacy.

4.2.3 Detached Buildings

Detached **storage, workshop buildings**, or other freestanding buildings (unless addressed in other sections of Design Guidelines) are not permitted.

4.2.4 Exterior Lighting

Except for “*Holiday Lighting*”, all **exterior lighting, including low level landscape lighting** must be submitted to and approved by the ACC, and should be a low-level, non-glare type and located to cause minimum visual impact to adjacent properties and streets. Exterior spotlights or floodlights must be hooded to eliminate glare onto adjacent properties and must not spotlight adjacent streets.

4.2.5 Bed Walls, Edging Material and Mulch

Landscaping must relate to the existing terrain and natural features of the lot, utilizing plant materials native to the Southeastern United States. The amount and character of the landscaping must conform to the precedent set in the surrounding community. The preferred landscape bed edging is a neat 3”-5” deep trench. Other types of edging should be of natural colors and materials, and should be four (4) inches or less in height. Decorative, professionally installed, designer poured concrete edging shall be approved by the ACC prior to installation. The concrete coloring shall blend into the surrounding area and be at ground level. All mulched landscape beds should be covered with natural pine straw or chopped pine bark mulch or small nuggets. No landscape gravel is allowed. No white landscape rocks are permitted for mulch.

Landscaping that involves regrading must be approved by the ACC in advance, must conform to Cherokee County soil disturbance regulations, and must not adversely affect drainage flows onto adjacent or downstream properties.

All beds shall be maintained, free of weeds and artificial materials and items. No pots, statues or brick-a-brak may be placed in the beds without approval from the ACC.

4.2.6 Plant Material

Front yards must be sodded with Bermuda or Zoysia turf grass, and be kept free of weeds or any other plant material that is not Bermuda or Zoysia grass. A minimum road shoulder of sod 6’ wide is required from lot line to lot line and including the entire street exposure of corner lots. Side and rear yards may be sodded, seeded or treated naturally, and may be Bermuda, Zoysia or Fescue.

Planting of ornamental plants and shrubbery in the front or side yards does not require prior approval. Any planting of trees must have approval.

All shrubbery in front of the house must be maintained no higher than the middle of the first floor window.

Ivy and other climbing plants and/or vines must be trimmed and must be kept from climbing houses, structures or trees, unless written permission is granted by the Board of Directors in

advance. Permission will not be granted for climbing plants on the front of homes, but will be considered on a case by case basis for areas that are originally planned and designed to incorporate climbing plants.

Plants should be planted in the ground. Pots may not be used in beds or the lawn as part of an ornamental design plan unless approved by the ACC.

Outdoor storage of garden tools and hoses must be completely screened from view. Preferably these items should be stored inside either garage or basement.

4.2.7 Animal Houses

Any structure to house household pets must be approved by the ACC. Animal house exterior colors and materials must relate to the exterior of the house or neutral in color. The structure should be completely screened from any view from surrounding properties and roads, and be discreetly located so as not to cause a nuisance to neighbors. Clothesline and/or fenced “dog runs” are not allowed.

4.2.8 Mailboxes

All mailboxes must conform to the approved design standard for the Arbors. Posts and boxes shall be black satin finish with gold numbers. Only one (1) mailbox per Lot is permitted. Landscaping around mailboxes shall be allowed, as long as the landscaping maintains a neat and clean appearance. Vines or other plant material which cover the residence number, or appear overgrown, are not allowed.

It is also the homeowner’s responsibility to keep the mailbox neat and in good order, and to repaint when needed. This is the one area that the ACC receives the most complaints about!

Painting a mailbox is not a difficult task. Should a homeowner elect to paint their mailbox, local hardware or paint stores sell **Rustoleum**, **Krylon**, or other consumer-oriented project paints. Select a paint that is **SATIN BLACK**, that indicates it is suitable for use on metal (or has a picture of it applied to metal), in either a spray can or a small can for brush-on (your preference). The instructions will explain to scrape or sand loose paint and rust, and to wash and rinse the mailbox. Follow the instructions on the can. Do not put anything on top of the paint, as peeling is caused by poor adhesion of the paint to the mailbox. **DO** sand or scrape the mailbox before applying your new paint.

There are also several ways you can spray paint your mailbox without painting the numbers or flag. One method is to use painting tape and cover the numbers and flag. Taping the numbers and flag is time consuming, and an alternative is to use Vaseline and apply a thick layer to the numbers and flag using your finger. Once the paint on the mailbox is dry, the Vaseline can be wiped off with a rag leaving the numbers and flag unpainted.

4.2.9 Fire Hydrants

Landscaping around fire hydrants is prohibited by the fire department and should be clear of any shrubs or bush. Low growing flowers are permitted, as long as they do not interfere with the tap mechanism.

4.2.10 Lawn Furniture

Any lawn furniture may not be placed in the front of residences, in front yards or any location where it will be visible from the street, including benches without approval of ACC prior to placement. Beach chairs, umbrellas, plastic furniture and/or brightly colored items will not be approved.

4.2.11 Yard Statuary and Ornamentals

Yard statuary is discouraged and must be submitted to the ACC for review.

Statuary, as defined here, does not include reasonably sized flowerpots or containers placed at or on the front entry or steps. Other statuary, such as but not limited to urns, animals, or human figures, should be modestly sized and displayed on or at the front entry, rather than in lawn or flower bed areas. Approval of statuary requests is solely at the discretion and aesthetic judgment of the ACC.

Statuary and ornaments submitted to the ACC for review must conform to the Community Wide aesthetic standards and must be made of either, wood, concrete, rock or metal; finished in traditional earth tone colors such as bronze, verdigris, black or natural-colored cement. Multi-colored or brightly-colored items will not be approved.

4.2.12 Gazebos & Arbors

Gazebos, arbors, etc. should be fully detailed (color samples, materials, site plan, elevations, details, etc.) and submitted for review. Site compatibility will determine approval of modification.

4.2.13 Swimming Pools & Hot Tubs

All swimming pools must fit naturally into the topography of the proposed lot and be located to provide minimal visual impact to surrounding properties and streets. Exterior hot tubs must be screened from adjacent properties and streets. All pump, filters, and equipment for spas must be located where it will not cause a nuisance to neighbors and must be screened from view.

In our experience, this is one of the most contentious issues between neighbors. As such, the ACC recommends that you talk to your neighbors before submitting any plans to the ACC for approval.

Under no circumstances will above ground swimming pools be permitted in the Community.

4.2.14 Tree Removal

Any tree removal must be approved by the Architectural Control Committee or their representative. Cutting, disturbing or otherwise impacting trees on property and easement is only permitted with written permission from the Architectural Control Committee.

Any tree removed without approval is subject to an immediate fine and the owner may be responsible to provide replacement tree(s). The current fine amount is two-hundred and fifty dollars (\$250.00), but is subject to change at any time without prior notice.

With regards to new pool construction, trees may only be cleared from the pool and decking footprint area.

Please refer to Cherokee County, Georgia for a list of approved trees.

4.2.15 Driveways

Driveways must be constructed of concrete and generally extensions and expansions will not be approved. Driveways may not exceed 20 feet in width at the road.

5. USE RESTRICTIONS & RULES (Image)

All Owners and Occupants of any Lot are subject to and are required to comply with the use restrictions contained in Article VI and in Article VII of the Master Declaration of our Covenants. The Board of Directors of the HOA may, from time to time, without consent of the members, promulgate, modify, or delete use restrictions and rules and regulations applicable to the Lots and the Common Property. This authority includes, but is not limited to, the right to limit the type and size and to set the maximum and minimum speeds of vehicles within the Community. The HOA also has the authority to impose all other necessary traffic and parking regulations and to restrict the maximum noise levels of vehicles in the Community. Such regulations and use restrictions would be distributed to all Owners and Occupants prior to the date that they are to become effective and would thereafter be binding upon all Owners and Occupants until and unless overruled, canceled, or modified in a regular or special meeting by a Majority of the Total Association Vote.

Any additional covenants imposed on the property within any Neighborhood may impose stricter regulations and use restrictions than those contained in, or adopted pursuant to, this Article of our Covenants.

The HOA has, over the years, made some minor changes to these Use Restrictions and Rules and has required the ACC to regulate and enforce them. This section covers most of the rules which the ACC may monitor and we have included hereunder our interpretation of the Covenants for the benefit of our Owners.

5.1 Architectural Standards

The Arbors Covenants Section 5.02 refers to powers and duties of the ACC: This rule is probably the most important and definitely the most enforced Covenant Rule within the Association. It is the reason for the existence of the Architectural Control Committee. (ACC).

All modifications to any part of the exterior of your property must be submitted for review and be approved in writing before any alteration is begun. This includes such items as tree removal, new walkways, arbors and any other landscaping ideas you may have. Even simple ideas like paint color changes must be submitted.

Design Guidelines can be found in this document. Don't be fooled by the words of the contractor you have engaged to do the work, rather check with the ACC.

Furthermore, ACC approval does **NOT** obviate the homeowner from seeking approval from any jurisdiction having authority over the project and vice versa.

5.2 Use of Lots

Lots are for single family residential purposes only. No business or business activity is permitted without the prior written consent of the HOA Board. Leasing of a lot is not considered a business activity, however all and any occupant of the lot are subject to the rules and regulations of the community.

5.2.1 Signs

No signs of any kind may be erected by any owner within the Community without the written permission of either the HOA or the ACC except:

1. Such signs as may be required by legal proceedings
2. Not more than one (1) "For Sale" sign of a maximum of four (4) square feet;
3. The approved community-wide standard security plaque mounted on the mailbox;
4. Yard of the Month plaque mounted on the mailbox for 30 days;
5. One Political sign in accordance with Cherokee County ordinances but not on common property.

5.2.2 Vehicles

No Vehicles may be parked on any street within the Community at any time, which includes cul-de-sacs. It is further stated that no Vehicle shall be parked on the Common Property or on any portion of a Lot other than the driveway and the garage, this includes sidewalks or on the grass.

The Association recognizes that this is a significant restriction, and makes every effort to be flexible in regards to occasional violations in this regard. Since many Owners require "extra space" for parking during "special functions" such as garage sales, dinner parties, etc., the HOA modified the rule, as follows: *"No Private Vehicle may be habitually parked on any street within the community. No overnight parking of any kind will be permitted."*

Except for "unmarked" automobiles (including minivans) and passenger trucks which are licensed and usually operable, vehicles may not be parked so as to be visible from any Lot for periods of more than twenty-four (24) continuous hours. The term "vehicles," includes, without limitation, motor homes, boats, trailers, motorcycles, scooters, trucks, campers, buses, and automobiles (including minivans). The term "unmarked", means not having prominently displayed and visible signs or markings on the exterior surface of the vehicle such as business names or phone numbers, commercial advertising or other similar markings (but not including license plate signs and window decals naming schools, athletic teams organizations and the like).

Commercial vehicles may be parked on a street for short periods of time, but never exceeding eight (8) hours, for the purpose of loading, unloading and/or while working on site, following these guidelines:

1. Only if the driveway is full or needed to render the service
2. Only during normal working hours (8 to 5)
3. All trailers must remain in-tow
4. Are not parked within 50 feet from a stop or yield sign
5. Are not parked within an intersection
6. Follow the one-side parking rule defined hereunder.

Under NO circumstances may any COMMERCIAL vehicle be left on a street overnight.

Should you partake in a “garage sale” function, part of your participation for the event requires you to comply with parking regulation which will usually stipulate on which side of the street prospective buyers may park. This will never be omitted and will never include BOTH sides. It is your responsibility to ensure that your visitors abide by this rule.

Similarly, should you have a dinner party or other function, or have commercial vehicles conducting services for you during any day, where they require more parking than you have in your driveway and need to park on the street, you may do so, following the guidelines in this section, provided: All your visitors must park only on one side of the street but should one of your neighbors already be parking in your immediate vicinity, all your guests should park on that side **ONLY**. No vehicle should be parked facing oncoming traffic. This will prohibit bottleneaking of roads, as is many times the case during Garage Sales, etc.

At **NO** time is any parking allowed **WITHIN** an intersection or **50** feet from a stop sign.

Commercial and Recreational Vehicles

For the purpose of clarification, the Arbors Covenants, Conditions and Restrictions and for these rules and regulations, “commercial truck” shall be defined as follows:

1. Panel trucks
2. Trucks with a cargo-load capacity of one ton or more
3. Vehicles typically used “for hire”, including, but not limited to, limousines and taxis (regardless of whether such vehicles are used “for hire” or for personal use), full-size vans (excluding vans specifically used by handicapped persons, mini-vans or sport utility vehicles used as passenger vehicles and receiving a “car” or “passenger vehicle” classification by the Georgia Department of Motor Vehicles),
4. Vehicles containing visible evidence of commercial use (such as tool racks, ladders, ladder racks or tow winches); provided, however, that vehicles with empty ladder or tool racks or standard tool boxes shall not be considered a commercial truck; and
5. Vehicles with commercial writings on their exteriors, including, but not limited to, vehicles with vinyl wrap advertising businesses, services or products. Marked law enforcement vehicles used for such purpose are specifically excluded from the definition of commercial truck.

Commercial trucks are prohibited from being parked in the Community except: (1) in garages with the garage doors closed; or (2) in the case of service vehicles, on a temporary basis during daytime business hours or during emergencies for the purpose of serving a Lot.

Boats, recreational vehicles, motor homes, trailers, motorcycles, minibikes, scooters, go-carts, golf carts, campers or mobile homes must be parked in the garage with the garage door closed; provided, however, such vehicles may be parked in the Community on a temporary basis not to exceed 24 consecutive hours. For the purpose of this provision, “temporary” shall mean no more than twice a year for a period not exceeding 24 consecutive hours.

Disabled and stored vehicles are prohibited from being parked in the Community longer than five (5) days. A vehicle shall be considered “disabled” if it does not have a current license tag or is obviously inoperable as provided in Article VI, Section 4 of the Master Declaration of Residential Owners Association. After five (5) days, such vehicle shall be considered a nuisance and may be removed from the Community. Recreational vehicles, boats, and similar vehicles stored or kept in the Community for longer than twenty-four (24) hours shall be considered a nuisance and may be towed.

Garages are not intended for storage. Residents are encouraged to park the maximum number of permitted vehicles for which the garage is designed in the garage.

Vehicles may not be parked on any grass or landscaped areas on Lots.

If any vehicle is parked in the Community in violation of the Declaration or these rules and regulations, the Board or agent of the Association may tow the vehicle after 10 days' written notice. Such notice shall: (1) be placed on the vehicle; (2) specify the nature of the violation; (3) warn of possible towing; and (4) state the name and telephone number of a person to contact regarding the violation. If 10 days after such notice is placed on the vehicle the violation continues or thereafter occurs again within six months of such notice, the Board or agent of the Association may have the vehicle towed in accordance with the original notice and without further notice. If a vehicle is parked in a fire lane, is blocking another vehicle or access to another Owner's or Occupant's Lot or dwelling, is obstructing the flow of traffic, is illegally or improperly parked on any Common Property, or otherwise creates a hazardous condition, no notice shall be required and the vehicle may be towed immediately from or on any Lot or the Community Property.

The Association's right to tow is in addition to, and not in limitation of all other rights of the Association, including the right to assess fines for violations of the foregoing rules and regulations and the terms of the Declaration.

Any vehicle parked in the driveway with a custom car cover shall follow all the same rules regarding length of parking. No tarps or other coverings are permitted on vehicles.

As a general rule, parking of vehicles on the street is prohibited. Temporary parking (4 hours or less) is allowed if not a nuisance to neighbors or impediment to traffic flows. Homeowners are responsible for guest parking and must ensure that guest's park in a safe manner and do not impede access to other driveways and traffic.

5.2.3 Animals and Pets

No animals, livestock, or poultry of any kind may be raised, bred, kept, or permitted on any Lot, with the exception of dogs, cats, or other usual and common household pets in reasonable number. Specifically, chickens will not be permitted on the Lot.

No pets may be kept, bred or maintained for any commercial purpose.

Dogs which are household pets, must at all times, whenever they are outside a Lot be confined on a leash. Without prejudice to the ACC's right to remove any such household pets, no household pet that has caused damage or injury to any other party or property, may be walked in the Community.

When walking your pet, it is your responsibility for cleaning up your pet's waste.

5.2.4 Unsightly or Unkempt Conditions

Lots must be maintained to community standards. Lawns must be regularly mowed and edged, beds mulched and weeded. Rear yards must be maintained to as a kept backyard. Owners may not let the yard to 'wild.'

The pursuit of hobbies or other activities, including specifically, without limiting the generality of the foregoing, the assembly and disassembly of motor vehicles and other mechanical devices, which might tend to cause disorderly, unsightly, or unkempt conditions, shall not be pursued or undertaken in any part of the Community. If these activities are undertaken within your own garage, have no adverse effect on your neighbors, does not create odors or noise pollutants, and does not affect the condition of your property as seen from the road, then the activity would not constitute a violation of this guideline.

5.2.5 Garbage Cans, Woodpiles, Hosepipes, Recycle

All garbage cans, woodpiles, garden hoses, ladders, wheelbarrows, and/or any other similar utilitarian items, must be located or screened so as to be concealed from view of any neighboring Lot and/or from the street.

Recycle Bins, Garbage and any Garden Waste may not be placed on the curbside earlier than 8:00 pm the night before collection and must be positioned off the street in such a manner that it does not create an obstruction for any oncoming traffic. Return cans to screened location after pickup, by no later than 12:00 p.m.

5.2.6 Flags

The Association follows the Federal Flag Code (PL 94-94-344; 90 Stat. 810; 4 United States Code sections 4 through 10), and any additional legislation regarding the display of the American / State of Georgia flags. The displaying of flags or banners, other than the flag of the United States of America, is discouraged except for special events or national holidays. If the homeowner elects to display a flag or banner (hereinafter referred to as flags), it must be done so in a manner consistent with the architectural objectives of the Association and must comply with the following:

- Number of Flags Allowed: Only one (1) flag, can be displayed unless it is a United States flag in conjunction with a military flag, in which case (2) flags can be displayed.
 - Subdued flags and/or “Tactical” flags are not allowed unless specific permission is given in writing by the Board of Directors
- Flag Size: Flag(s) can be no larger than 3’x5’, unless it is a United States flag, in which case it can be no larger than 4 1/2’ x 6’.
- Flag Poles: Flag pole holders must be mounted to the house and painted to match unless displaying a United States flag. No flags are to be mounted to trees. A flag pole or holder that is mounted to a home can be no longer than six (6’) feet.
- Flag Display: Flags mounted to homes cannot be displayed higher than ten (10’) feet above the finished grade elevation.
- All flags are subject to Modifications Committee approval, except the current flag of the United States of America.
- All flags must have appropriate lighting from dusk to dawn
- Small flags on holders may be permitted but are subject to Modifications Committee approval.
- Seasonal, Decorative and Additional Flags:
 - Additional flags include Military and sports flags
 - Holiday, Seasonal, and Decorative flags. Holiday flags are subject to time limit rules spelled out in this document.
 - Flags of other nations or flags that are objectionable (such as a swastika) are prohibited.

- Flags must be kept in like-new condition
- The Board of Directors shall be the arbiter of the appropriateness of decorative flags, should questions arise.
- Display for National Holidays
 - The Association permits display of a reasonable number of additional American flags on the following National Holidays only (to be removed not later than 5:00 P.M. of the following day):
 - i. President's Day
 - ii. Armed Forces Day
 - iii. Memorial Day
 - iv. Flag Day
 - v. Independence Day, July 4th
 - vi. Labor Day
 - vii. Patriot Day (September 11)
 - viii. Veteran's Day

APPENDIX A: Approved Fencing

The following are the only approved stain colors for use:

1. Espresso
2. Walnut
3. Cypress
4. Transparent / Clear

A.1 Shadowbox Privacy Fencing

This type of fence creates equal finishing on both sides.

1. Shadow Box
2. 4"x4" Posts
3. 1"x6" Boards; 60" in height (5 Feet)
4. Cedar or comparable wood
5. 3-4" between boards, covered on the opposite side by similar dimensions
6. Supporting posts must not exceed the height of the fence boards
7. Maximum height for fence is 60" (5 Feet)

Straight Shadowbox

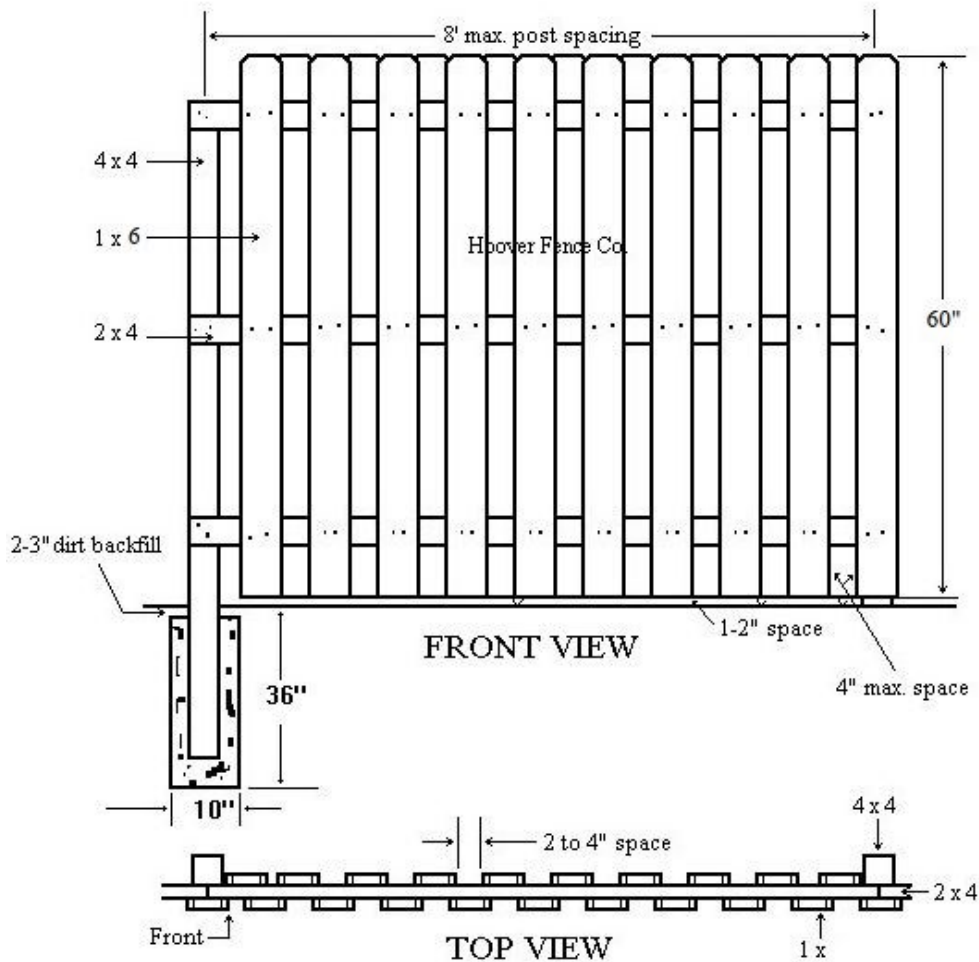

A.2 Cedar Split Rail Fences



1. Where fences face Corps of Engineers property, fences must be erected at least 8-inches inside the owner's property.
2. Black wire mesh on interior portion is permitted.
3. Common fences are permitted with written approval from neighbors, where it may be erected on the common property line.
4. Other substitutes such as "Appalachian Treated Pine" will be considered as alternative woods.
5. Two or three level cross rail members are permitted. (Three level cross rail members shown in picture.)

A.3 French Gothic Spaced:

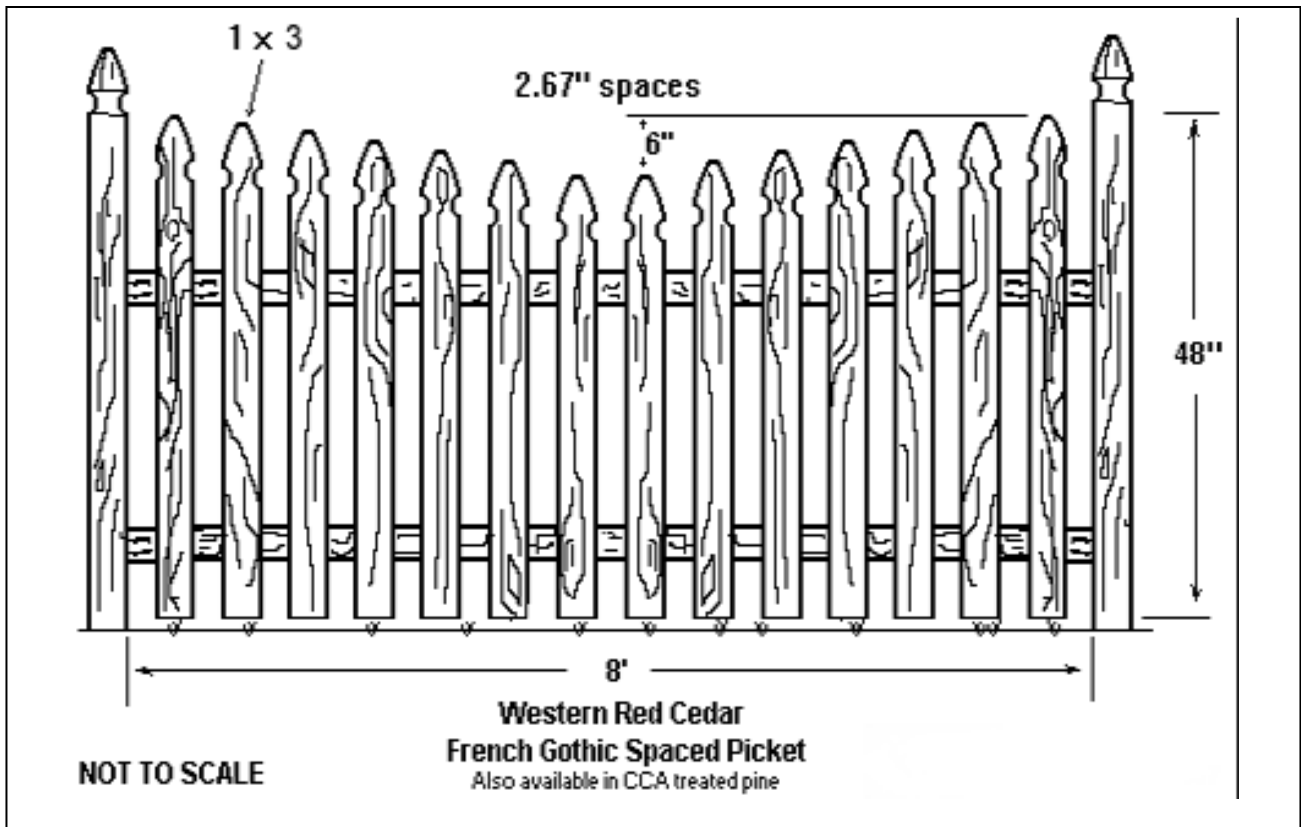

A.4 Wrought Iron or Aluminum Fencing:



1. 5/8" Pickets
2. 3 13/16" to 4" spacing between pickets
3. 2" metal posts or 12" brick or stucco posts that match house
4. 6' lengths between posts
5. 42", 48", or 60" heights only